

Open Eyedeas.com



Graphic Design &  
Digital Photography



George Baltzegar

404.617.6206 • [george@openeyedeas.com](mailto:george@openeyedeas.com) • P.O. Box 1367 • Buchanan, GA 30113

Thank You for your interest in **Open Eyedeas**.

**Our goal is to thrill you by providing graphics and photography solutions which represent your products and services to your target market at an affordable price!**

How do we accomplish this?

Give us a call or send an email to begin the communication process.

We will discuss:

**who you are  
what you do  
what is your target market  
what is your budget  
what is your time frame**

Based on our discussion, Open Eyedeas will present you with an estimate and scope of work to complete your solution. New clients and estimates over \$1,000 will require 50% of estimate to begin project. Remainder will be due upon completion/delivery of project.

Our services include the design and/or production of:

**Corporate Identity  
Postcards  
Sale Sheets  
Brochures**

**Catalogs  
Presentation Folders  
Print Advertisements  
Product Development**

**Packaging  
Point of Purchase Displays  
Trade Show Displays  
Product Photography**

The next several pages are designed to give you a better understanding of our process and pricing to complete a project. We hope you find this information helpful and allow us the opportunity to earn your business.

George Baltzegar  
Owner  
Open Eyedeas



**George Baltzegar**

**404.617.6206 • [george@openeyedeas.com](mailto:george@openeyedeas.com) • P.O. Box 1367 • Buchanan, GA 30113**

**Project:**  
Magazine Ad

**Purpose:**  
To design ad promoting the products, services  
and location of BEBO Powersports.

**Client:**  
Community Magazine, LLC.

**Client Provided:**  
BEBO Powersports concept logo  
Ad information

**Open Eyedeas:**  
Created logo from concept  
Provided 2 royalty-free images  
Created background image  
Worked with sales rep for product photos  
Designed map and ad layout

**Price:**  
Created logo from concept - \$100  
Provided 2 royalty-free images - \$50  
Created background image - \$150  
Minor adjustments to 4 product photos - \$100  
Designed map and ad layout - \$200

**Total Project Cost - \$600**



**BEBO POWERSPORTS**

- > Arctic Cat
- > Honda
- > Suzuki
- > Kawasaki
- > Yamaha
- > Joyner
- > Motorcycle & ATV

**10% Off**  
Parts & Accessories  
Excludes Labor. Must Present This Ad. Expires 02/31/08

**678-363-8228**  
**Buy > Sell > Trade > Parts > Accessories > Service**

**www.bebopowersports.com**



George Baltzegar  
404.617.6206 • [george@openeyedeas.com](mailto:george@openeyedeas.com) • P.O. Box 1367 • Buchanan, GA 30113

**Project:**  
Sale Sheets

**Purpose:**  
To inform clients about products, provide item numbers, flavors and product specifications for placing orders.

**Client:**  
Custom Beverage Concepts

**Client Provided:**  
CBC logo  
Stock photography images  
Product descriptions  
Product chart information

**Open Eyedeads:**  
Designed concept, layout and charts to function with all products and information  
Performed minor color correction and retouching on images  
Provided high quality PDFs to client for their sales team

**Price:**  
First layout - \$250  
7 additional layouts - \$100 each

**Total Project Cost - \$950**



**SMOOTHIES & ICE COFFEE**

**Custom Beverage CONCEPTS**

The "Ice Age" is back!

Always in season, ARCTIC FREEZE SMOOTHIES and JAVA FREEZE FROZEN COFFEE are all the rage. Blended for superior taste and creamy, smooth texture, these delightful treats are always a hit.

ITEM No.	PRODUCT	NET Wt.	PACK	CASE Wt.	PALLET	CUBE	YIELD Per CASE
10017	Arctic Freeze Blue Raspberry Smoothie	2lb	6 / 2lb	13lb	15 / 6 / 90	.35cu ft	10 gallons
10018	Arctic Freeze Pina Colada Smoothie	2lb	6 / 2lb	13lb	15 / 6 / 90	.35cu ft	10 gallons
10019	Arctic Freeze Cherry Smoothie	2lb	6 / 2lb	13lb	15 / 6 / 90	.35cu ft	10 gallons
10022	Arctic Freeze Strawberry Smoothie	2lb	6 / 2lb	13lb	15 / 6 / 90	.35cu ft	10 gallons
ITEM No.	PRODUCT	NET Wt.	PACK	CASE Wt.	PALLET	CUBE	YIELD Per CASE
10015	Java Freeze French Vanilla Frozen Coffee	1.5lb	8 / 1.5lb	13lb	15 / 6 / 90	.35cu ft	10-12 gallons
10016	Java Freeze Mocha Frozen Coffee	1.5lb	8 / 1.5lb	13lb	15 / 6 / 90	.35cu ft	10-12 gallons

344 Golf Course Road • Tallapoosa, GA 30176  
phone: 770.574.9899 • fax: 770.574.3095 • custombeverageconcepts.com

**BULK BLENDS**

**CAPPUCCINO**

**CAPPUCCINO TOPPING**

**DRINK MIX**

**HOT CHOCOLATE**

**TEA SWEETENER**

**VENDING**

**Project:**

Logo, Business Card and Brochure

**Purpose:**

To establish corporate identity, promote and inform clients about products and services provided by new business.

**Client:**

Your Basement Store

**Client Provided:**

Product and service information  
Transportation to on site photography

**Open Eyedeas:**

Designed logo  
Designed and printed business cards  
Provided on site photography  
Provided stock photography  
Designed and printed brochures

**Price:**

Designed logo - \$350  
Designed 4/4 business cards - \$100  
3,000 printed business cards - \$150  
Half day of on site photography - \$500  
13 stock photography images - \$325  
Designed bi-fold brochure - \$400  
2,500 printed brochures - \$500

**Total Project Cost - \$2,325**



George Baltzegar  
404.617.6206 • george@openeyedeas.com • P.O. Box 1367 • Buchanan, GA 30113

**Project:**

Bottle Opener, Cap Catcher and Combination Product Development

**Purpose:**

To produce products and images for print and web site advertising.

**Client:**

Brown Manufacturing Company

**Client Provided:**

Blank products for photography  
Logos for licensed products

**Open Eyedeas:**

Photographed blank products for logo applications  
Created product image templates  
Designed logos for products  
Produced images for print and web site use

**Price:**

Photographed blank products for logo applications - \$150 each  
Created product image templates - \$50 each  
Designed logos for products - \$75 each  
Produced images for print - \$50 each  
Produced images for web site - \$8 each  
Created online catalog - \$200 each page

**Total Project Cost**

New Product Images average between \$58 - \$183 each

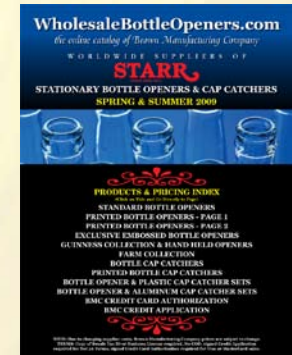

For a complete line of Brown Manufacturing wholesale products, go to:  
[www.wholesalebottleopener.com](http://www.wholesalebottleopener.com)



George Baltzegar

404.617.6206 • [george@openeyedeas.com](mailto:george@openeyedeas.com) • P.O. Box 1367 • Buchanan, GA 30113

**Project:**

Packaging Cooler

**Purpose:**

To design large folding cooler for seafood company to distribute their products while maintaining freshness and promoting their company image.

**Client:**

Laminating Technologies, Inc.

**Client Provided:**

Markesa company logo  
Large cooler die line

**Open Eyedeas:**

Corrected die line and added bleed area  
Provided rights-managed lighthouse image  
Manipulated image to fit die areas  
Designed 3-D layout  
Produced sample and final production art

**Price:**

Corrected die line and added bleed area - \$75  
Rights-managed lighthouse image - \$500  
Manipulated image to fit die areas - \$225  
Designed 3-D layout - \$450  
Produced actual size sample - \$195  
Provided final production art - \$75

**Total Project Cost - \$1,520**

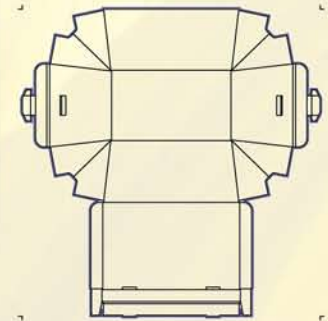

George Baltzegar

404.617.6206 • [george@openeyedeas.com](mailto:george@openeyedeas.com) • P.O. Box 1367 • Buchanan, GA 30113

**Project:**

Catalog, Order Form and Credit Application

**Purpose:**

To inform clients about product line, provide item numbers, product specifications and necessary forms for placing orders.

**Client:**

Trademark Marketing International, Inc.

**Client Provided:**

TM logo

Products for photography

Product descriptions and ordering information

**Open Eyedea:**

Designed concept and layout of catalog

Revised order form and credit application

Photographed, color corrected, retouched and clipped all new product images

Produced complete 2007 catalog

**Price:**

Design 20 page catalog - \$5,000

Revise 6 page order form and credit application insert - \$400

Photograph and prepare 41 new product print ready images - \$6,950

Produced 8,000 complete catalogs - \$6,920

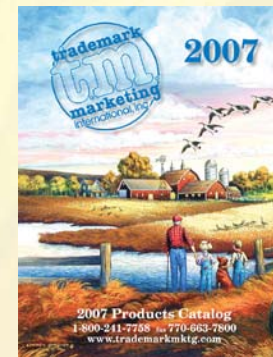
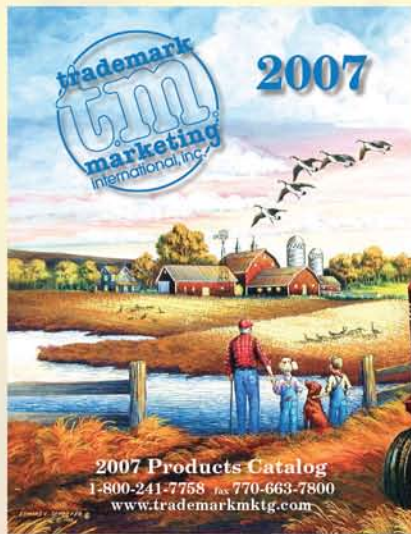
**Total Project Cost - \$19,270**To view the complete catalog, [Click Here to download PDF.](#)

George Baltzegar

404.617.6206 • [george@openeyedea.com](mailto:george@openeyedea.com) • P.O. Box 1367 • Buchanan, GA 30113



I hope the previous pages provided useful information that will allow me the opportunity to earn your business. For more examples of my work, please visit

[www.openeyedeas.com](http://www.openeyedeas.com)

I appreciate your consideration,  
George Baltzegar  
Owner  
Open Eyedeas

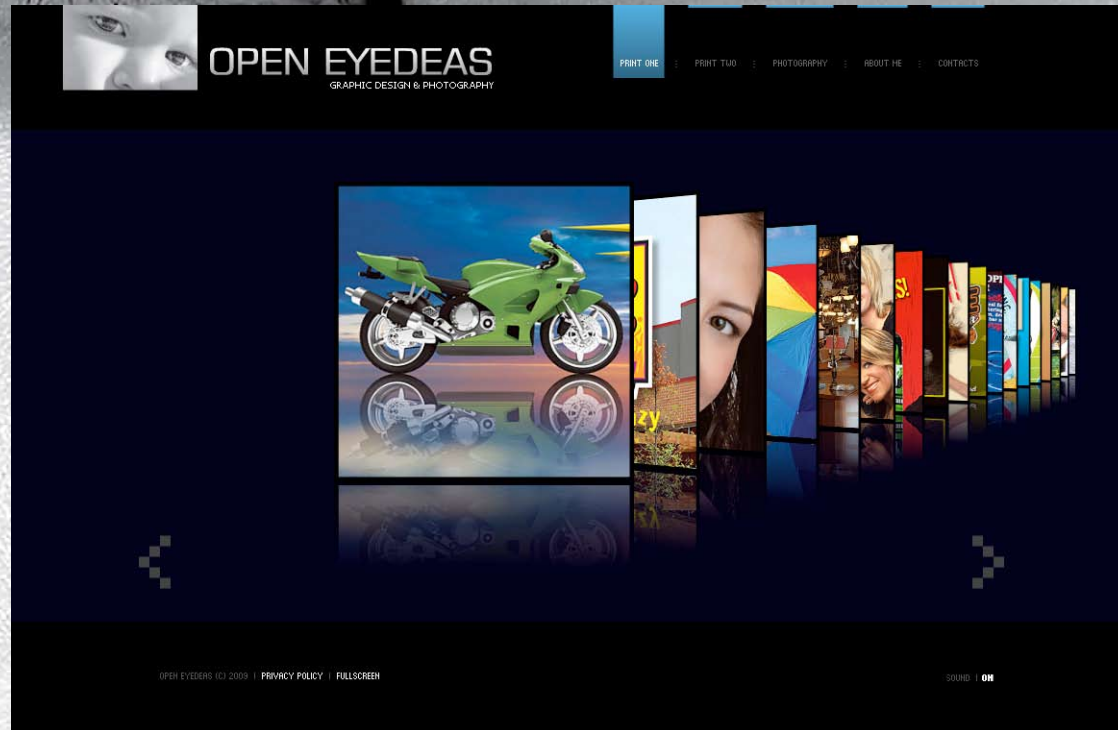

George Baltzegar  
404.617.6206 • [george@openeyedeas.com](mailto:george@openeyedeas.com) • P.O. Box 1367 • Buchanan, GA 30113